



tt577

Multispot laser

for all your retinal needs

your laser specialist

meridian 
medical



SUPERIOR QUALITY & LONGEVITY

Meridian Medical reserves its best laser cavities using the highest quality components for our premium laser range. We have strategically partnered with the top ophthalmic industry manufacturers to include the absolute best quality components from Switzerland and Europe in our multispot range. Meridian's propriety scanning systems feature the fastest galvanometers on the market, assuring perfect patterns and laser quality at all times.

These systems are meticulously integrated at our facilities, providing the best and most reliable integration platform combined with Haag-Streit slit lamps. The TT housing encloses all peripheral fibre and cables increasing its protection whilst the dust-free aluminium case safeguards the inner electronics.



tt577

USABILITY

Designed by European retinal specialists, TT offers a high level of practical and relevant features:

- Retinal projection: laser settings, laser power, pattern selection, size, and rotation are observed through the oculars eliminating the need of removing the eyes from the slit lamp. Thus, maximising the efficiency of the surgeon when performing the treatment
- Except spot size, all laser parameters can be modified through the touch screen (e.g. power, pattern, duration)
- Furthermore, our proprietary 3D Mouse interface makes the laser operation fast, easy, and Intuitive. Power and pattern (type, size, position) can be swiftly modified by using the 3D Mouse.
- These advanced features help to speed up the treatment time and reduce patient chair time



your laser specialist



SAFETY

Meridian's multispot range includes the highest degree of safety features in pattern laser photocoagulation.

- Restricted pattern size by 2×2 mm
- Automatic fluence calculation combined with spot size control and laser lens power
- Limited total time of pattern delivery to 0.7 seconds
- Retinal outline projection of patterns to ensure the visibility of tissue and grid location
- Pattern delivery stops by releasing the foot pedal
- The table height is automatically locked when the laser is in "ready mode"





FLEXIBILITY & COMFORT

We understand customers like to have the option and control, if Haag-Streit BQ 900 is not your preferred bio-microscopy we can provide our pattern lasers with CSO SL 9900.

- All Meridian systems are installed and calibrated by our worldwide network of factory trained distributors and engineers.
- TT range slit lamp scanners ensures excellent retina illumination and laser delivery.
- Meridian offers the flexibility of 3 multispot models to cater any customer needs





CLINICAL INDICATION

Meridian Medical's multispot lasers are designed to satisfy the needs of retinal photocoagulation. Our lasers will deliver superb laser quality with the highest optical quality available in the industry when treating the retina. Whatever your treatment parameters and preferences are, Meridian's multispot range offers solutions to cater to your need in a compact and versatile unit.

Photocoagulation:

Retinal photocoagulation, panretinal photocoagulation (PRP) and photocoagulation of vascular and structural abnormalities of the retina and choroids, including:

- Proliferative and non-proliferative diabetic retinopathy
- Choroidal neovascularization
- Branch retinal vein occlusion
- Age-related macular degeneration
- Retinal tears and detachments
- Retinopathy of prematurity
- Macular edema
- Lattice degeneration
- Central retinal vein occlusion

Trabeculoplasty:

Trabeculoplasty in open angle glaucoma



WAVELENGTH BENEFITS – WHY 577 nm?

- The yellow wavelength 577 nm causes less retinal burns and therefore less scotoma formation
- This gives the physician better control over the interaction between the laser beam and tissue
- The yellow light is not absorbed by xanthophyll, making it ideal for macular treatments
- Because it also produces less scattered light, it penetrates existing opacities better and reaches the tissue more precisely

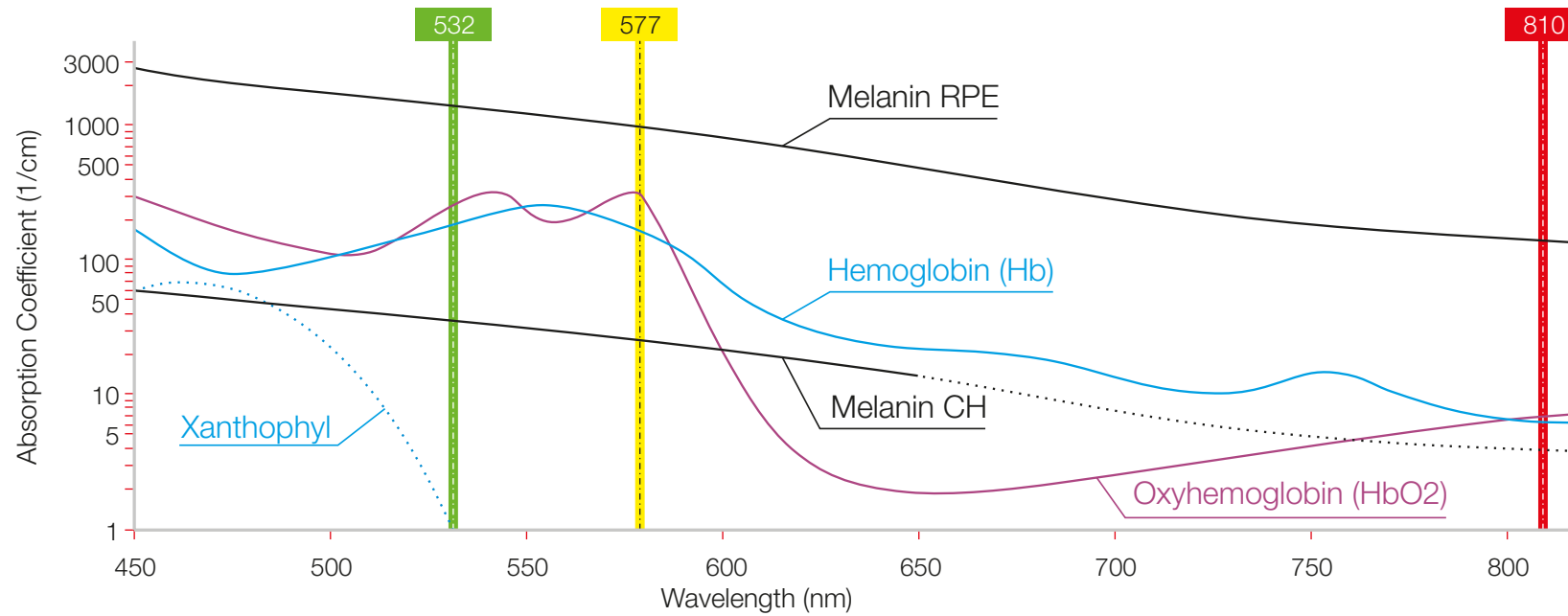



LASER MODALITIES

TT range delivers continuous wave laser and Meridian Medical copyrighted microsecond pulses technology shortpulse.

Continuous wave (CW) mode has been around since 1961 and it's the standard mode of treatment, pattern lasers have popularised shorter pulses of 10, 20 & 30 ms and new shorter pulses (microsecond pulses) have established as new paradigm in the subthreshold retinal treatment.

Meridian photocoagulators offer all modalities, CW, pattern short millisecond pulses and microsecond shortpulse technology.

Shortpulse delivers small pockets of chopped energy during a specific duty cycle applying less thermal strain allowing improved tissue relaxation and no visible damage on the retina.

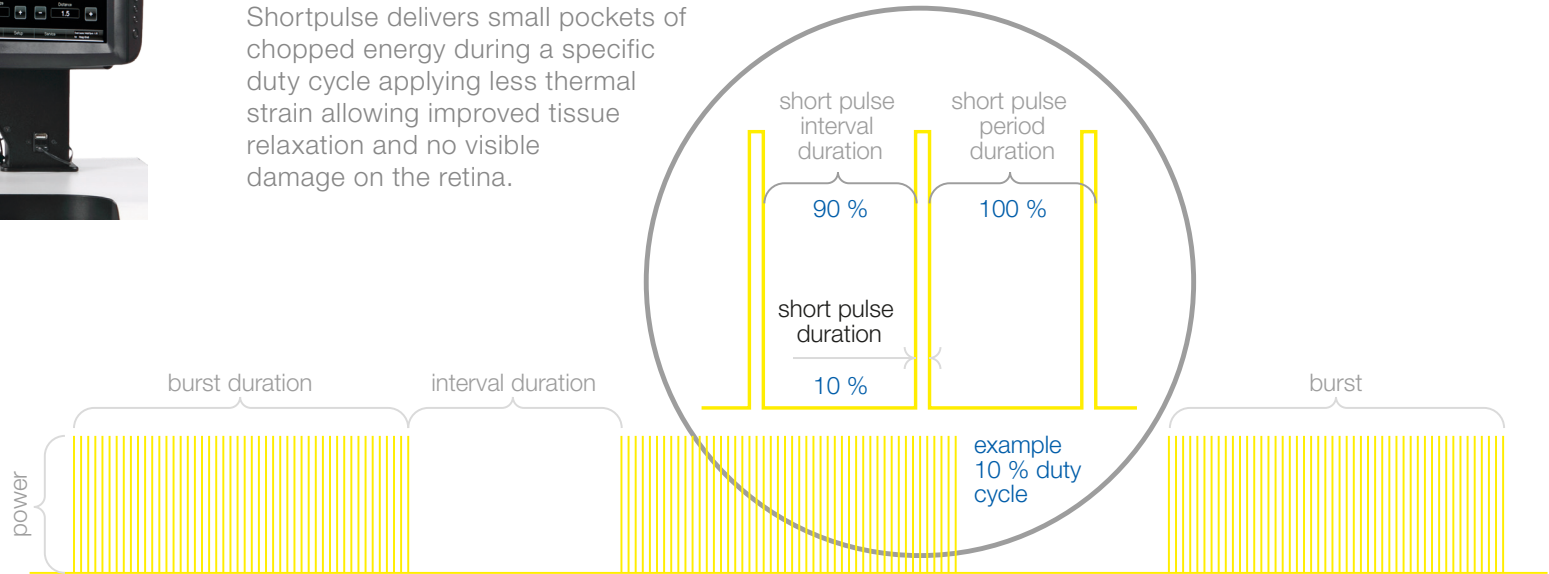

SELECTING A PATTERN AND PATTERN ROTATION

Pattern selection and rotation depend on user preference, on the pathology and on the curvature of the eye. The full pattern must be visible and in focus on the retina, avoiding direct coagulation of blood vessels.

SELECTING A CONTACT LENS

The contact lens will be chosen according to the position of the lesion and personal preference. The software calculates the actual spot size on the retina depending on the lens selected by the user.

SELECTING SPACING

The ETDRS (Early Treatment of Diabetic Retinopathy Study) recommendation for PRP is 0.5 burn spacing for short pulsed lasers because there is less thermal diffusion. Confluent (0) spacing will be chosen when creating a barrage around tears or holes.

SELECTING PULSE DURATION

It is recommended to start with 20 ms for peripheral treatments and 10 ms for macular treatments. If in doubt, start with a longer pulse duration and low power.

SELECTING FLUENCE

Start with low power in single spot mode and observe the effect on the tissue. Titrate upwards until the desired effect is seen on the tissue. Wait a few seconds to observe the effect as shorter pulses take longer to become visible. The fluence is calculated and displayed on the screen. Fluence delivered in a pattern will always be less due to the shorter pulse duration.

NUMBER OF SPOTS

To be effective and obtain regression of NV with 20 ms pulse duration it is necessary to deliver at least 50%.

PHOTOCOAGULATION – TREATMENT GUIDELINES FOR SHORTPULSE LASERS

These guidelines have been prepared following industry standards for retinal treatments, the use of the laser and its parameters are responsibility of the treating ophthalmologist.

Procedure	Spot size(*)	Exposure	Starting power	Spacing	Pattern
PRP (Central)	100 – 200 µm	0.01 s	100 mW	0.5 – 0.75	Arc
PRP (Periphery)	200 – 500 µm	0.02 – 0.03 s	400 mW	0.5 – 0.75	Square
DME (Focal)	50 – 100 µm	0.01 – 0.02 s	100 mW	0 – 0.5	Arc
DME (Grid)	50 – 200 µm	0.01 s	100 mW	0 – 0.5	Square
Tears & Breaks	50 – 1000 µm	0.03 s	400 – 600 mW	0	Line 1-2-3
Degenerations	500 – 800 µm	0.03 s	400 – 600 mW	0.25	Line 1-2-3

(*) Spot size on macula including the lens magnification factor

Suggested parameters for the Posterior Segment taken from Bloom & Brucker (1997) "Laser Surgery of the Posterior Segment"

Sanghvi et al. Initial experience with the Pascal photocoagulator: a pilot study of 75 procedures. Br J Ophthalmol. 2008

Bandello et al. Light panretinal photocoagulation (LPRP) versus classic panretinal photocoagulation (CPRP) in proliferative diabetic retinopathy. Semin Ophthalmol. 2001

Nagpal et al. Comparison of laser photocoagulation for diabetic retinopathy using 532-nm standard laser versus multispot pattern scan laser. Retina. 2010

TREATMENT END-POINT

depending on the disease or disease:

Sealing (holes, tears)	aim for a full-thickness, visible strong grey burn
Tissue photocoagulation (PRP)	the brighter (whiter) the burn, the more thermal spread will be observed but this will require longer pulse times or higher fluences. Shorter pulse times (e.g. 20 ms) and lower fluences will result in barely visible light grey burns
Stimulation, reduction edema (macular grid)	aim for an only barely visible effect. Note that with short pulse durations, the burn takes longer to become visible. Wait a few seconds when titrating to allow for full effect



STANDARD ACCESSORIES

Meridian multispot range comes standard with:

- Scanning slit lamp delivery systems
- Footswitch
- Safety goggles

TT range includes the twin-column table for great patient access.



TECHNICAL SPECIFICATIONS*

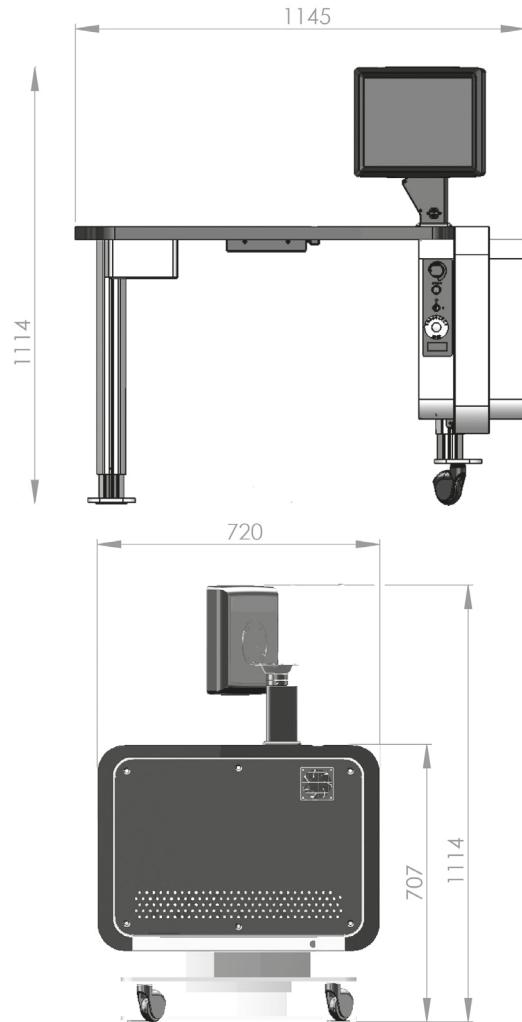

Device description	Multispot laser tt577
Laser	OPSL 577 nm
Laser Power	50 – 1500 mW
Pulse duration (CW)	Single 10-650 ms Pattern 10-30 ms
Shortpulse	Duty cycle: 5 - 50 % Shortpulse period duration: 2 ms (fixed) Shortpulse duration: 100 µs (5 %) up to 1000 µs (50 %) Pattern: 100 ms/spot (burst of 50 shortpulses)
Spot sizes	50 µm, 100 µm, 200 µm, 300 µm and 400 µm
Aiming beam	635 nm, adjustable brightness. Pattern projected as spot or outline
Patterns	Square, Circle, Arc, Sector, Line, Spot (repetition)
Laser cooling	TEC
Computer cooling	Fan cooling
User interface	15" Touch screen and Smart Wheel (3D Mouse)
Slit lamp	Haag-Streit BQ 900 or CSO SL 9900
Electric	230 V 50 Hz (Voltage options for different countries are available)
Net Weight	138 kg
Gross Weight	208 kg

* All technical specifications are subject to change without notice. In accordance with the international general safety standards: IEC 60601-1:2005/AMD1:2012, IEC 60601-1-2:014, MDD 93/42/EEC. The laser safety is in accordance with the international standards: IEC 60825-1:2014 and IEC 60601-2-22:2007/AMD1:2012.





Head office

Meridian Medical Group

Tel.: +41 33 334 11 11
Fax: +41 33 334 11 19
info@meridian.ch
www.meridian.ch

Switzerland

Meridian AG

Biergutstrasse 7
CH-3608 Thun

Slovenia

Meridian Medical d.o.o.

Plemljeva ulica 8
SI-1210 Ljubljana-Šentvid

Finland

Meridian Medical Oy

Elannontie 5
FI-01510 Vantaa